

FO Code: 001670

Refn.70501 1577

Version: 2021/12/06

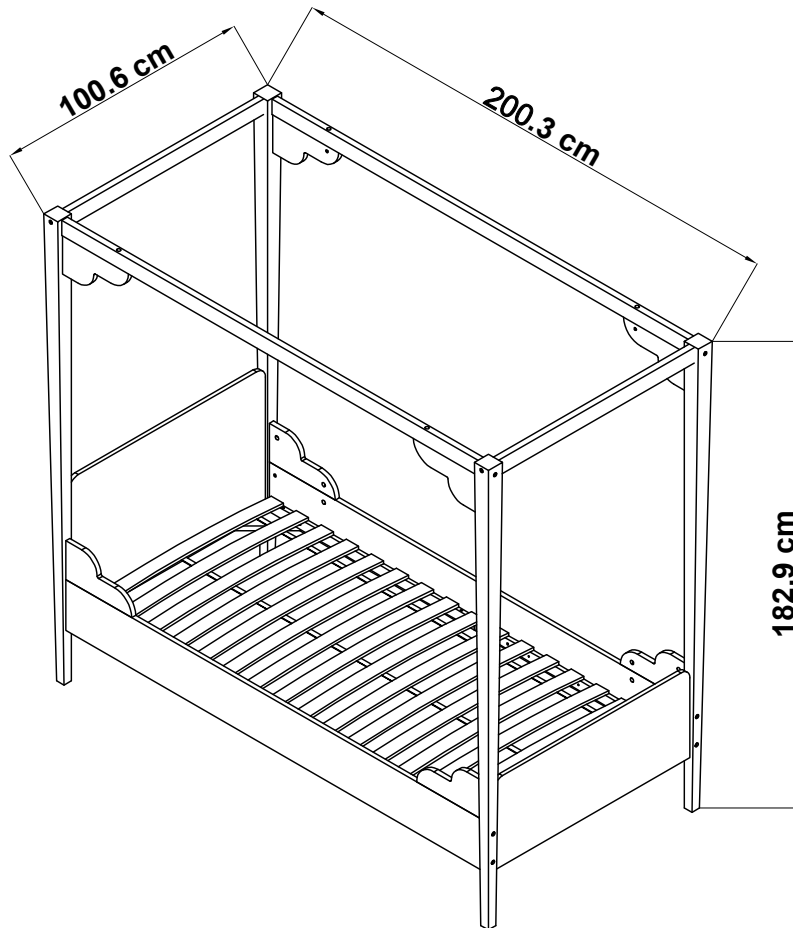

- Vor Montage den Inhalt Ihres Päckchens kontrollieren
- Die Verpackung nicht zerstören, sie wird Ihnen nützlich sein, um die Teile bei der Montage vor Stößen und Kratzern zu schützen
- Das Möbel dann in der Reihenfolge der Nummerierung zusammenbauen
- Im Problemfall Ihren Kundendienst anrufen
- Lüften Sie Ihre Möbel nach dem Aufbau bitte mit geöffneten Möbeltüren und-schubladen in einem gut durchlüfteten Raum.



- Controlar el contenido de su embalaje antes de proceder al montaje
- No deteriorar el paquete, que le será muy útil para proteger los elementos de golpes y rozaduras durante el montaje.
- Acoplar de seguida el mueble, siguiendo la orden definida por la numeración
- Si tiene problemas, contactar nuestro servicio postventa
- Desde la recepción, ventilar los muebles, con las puertas y cajones abiertos, en una estancia bien ventilada. Renovar regularmente el aire de las estancias



- Verificare il contenuto della confezione prima del montaggio.
- Non eliminare l'imballo che potrà essere utilizzato per proteggere il prodotto dai danni durante il montaggio.
- Montare l'articolo seguendo l'ordine di numerazione.
- In caso di necessità contattare il nostro servizio post-vendita.
- Al ricevimento, areare i vostri mobili, aprendo porte e cassetti, in una stanza ben ventilata. Ricambiare l'aria della stanza regolarmente



- De Inhoud van uw pakket controleren alvorens met de montage te beginnen
- De Verpakking niet beschadigen, deze kan heel handig zijn om de onderdelen te beschermen tegen schokken en krassen tijdens de montage.
- Zet vervolgens het meubel in elkaar in de volgorde die is bepaald in de nummering
- Neem bij problemen contact op met onze klantenservice.
- Laat na ontvangst uw meubels luchten (deuren en laden open) in een goed geventileerde ruimte. Zorg regelmatig voor frisse lucht in uw kamer



- Contrôler le contenu de votre colis avant de procéder au montage.
- Ne détériorez pas l'emballage, il vous sera très utile pour protéger les éléments des coups et rayures pendant le montage.
- Assemblez ensuite le meuble en suivant l'ordre défini par la numérotation.
- En cas de problème contactez notre service après-vente.
- A réception, aérer vos meubles, portes et tiroirs ouverts, dans une pièce bien ventilée. Renouveler régulièrement l'air de vos pièces.



- Check the content of your parcel before assembling.
- Do not throw away the packing which could be very useful to protect the panels from knocks and scratches when assembling.
- Assemble the article following the order of the numbers indicated.
- Should any problems arise, please contact our After Sale Service.
- Upon receipt, place the furniture in a well-ventilated room and leave doors and drawers open to allow the air to circulate. Change the air in your rooms on a regular basis.



- Confira o conteúdo da sua encomenda antes de iniciar a montagem.
- Não danifique a embalagem, poderá ser-lhe útil para proteger os elementos de golpes ou riscos durante a montagem.
- Proceda à montagem do móvel seguindo a ordem definida pela numeração.
- Para qualquer esclarecimento, contacte os nossos serviços através do telefone.
- Aquando da sua recepção, arejar os seus móveis, portas e gavetas abertos, numa divisão bem ventilada. Renovar regularmente o ar das suas divisões.

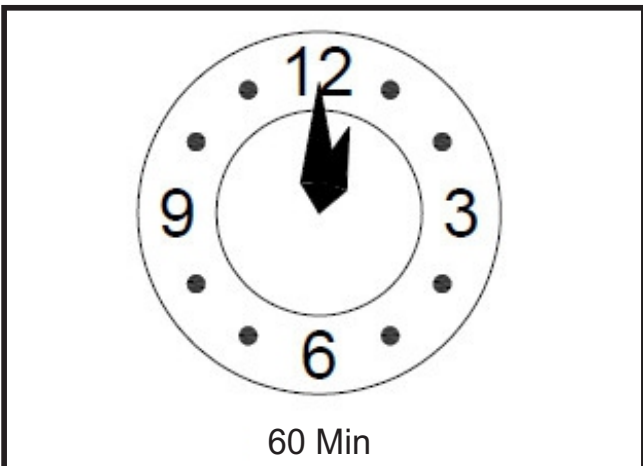
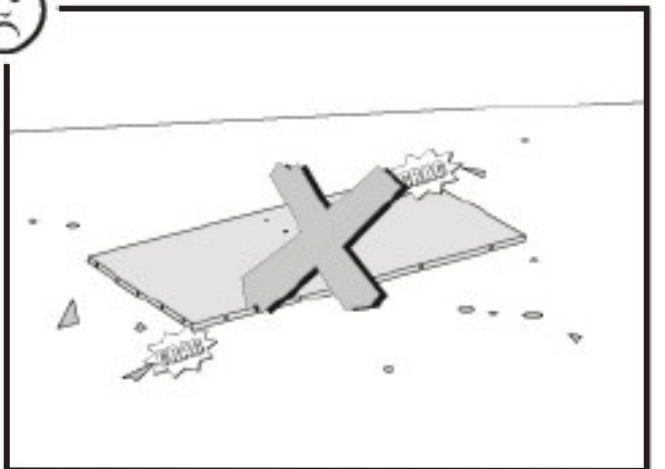
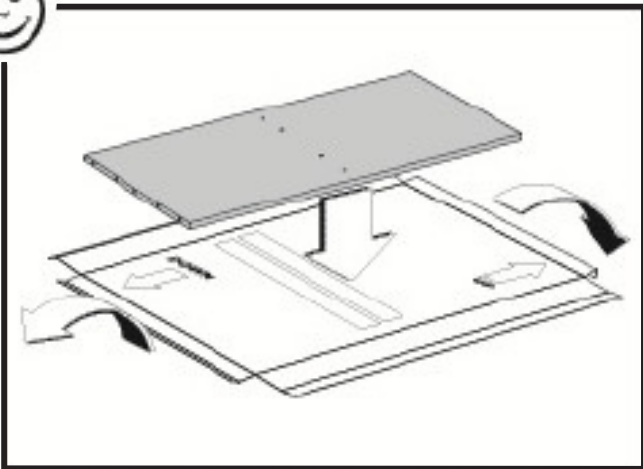
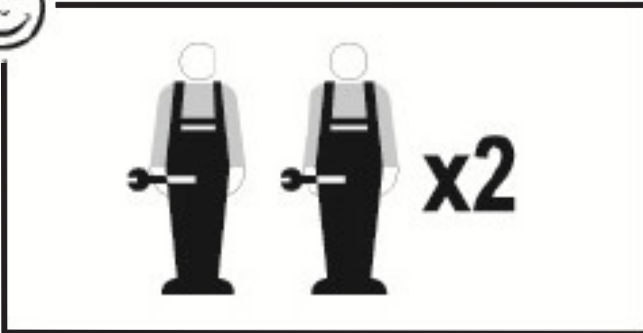
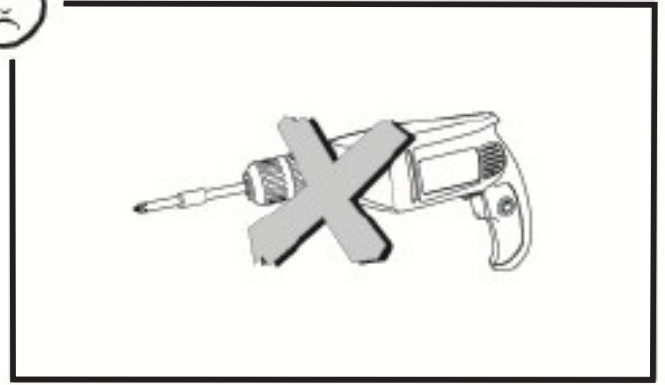
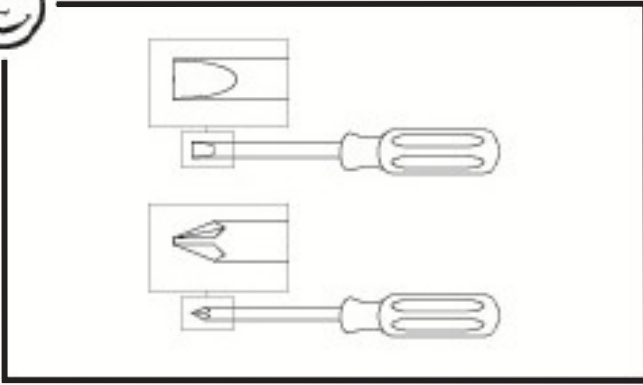

FR - Notice de montage / EN - Assembly instructions / PT - Instruções de montagem / ES - Prospecto de montaje / DE - Montageanleitung / IT - Istruzioni di montaggio / NL-Montagehandleiding

FR - IMPORTANT! CONSERVER POUR CONSULTATION ULTERIEURE: LIRE ATTENTIVEMENT

- A monter par un adulte. Un adulte doit vérifier le bon assemblage avant l'emploi
- **ATTENTION!** tenir les vis et petits éléments et sachets hors de portée des enfants
- Bien identifier les éléments avant de commencer le montage
- Ne pas utiliser votre article lorsque l'un de ses éléments est cassé ou manquant
- En cas de problème contactez notre service après-vente
- Toujours suivre les instructions du fabricant
- Entretien: nettoyer avec un chiffon doux et sec. En cas de taches plus grosses, frottez soigneusement avec une éponge légèrement humide et non abrasive
- **ATTENTION!** Ne convient pas aux enfants de moins de 3 ans. Petits éléments. Danger d'étouffement.

EN - IMPORTANT! KEEP FOR FUTURE REFERENCE: READ CAREFULLY

- To be assembled by an adult. Assembly must be checked by an adult before use
- **WARNING!** keep all screws, small parts and plastic bags out of the reach of children
- Properly identify all parts before assembling
- Never use your item if any of its parts are broken or missing
- Should any problems arise, please contact our After Sales Service
- Manufacturer's instructions shall be followed at all times
- Care: clean with a soft, dry cloth. In case of larger stains, carefully rub with a slightly damp, non-abrasive sponge
- **WARNING!** Not suitable for children under 3 years. Small parts. Choking hazard.

PT - IMPORTANTE! GARDE PARA CONSULTA POSTERIOR: LER ESTAS INSTRUÇÕES CUIDADOSAMENTE

- A ser montado por um adulto. Um adulto deve verificar a boa montagem antes da utilização
- **ATENÇÃO!** mantenha os parafusos, acessórios pequenos e saco de plástico fora do alcance das crianças
- Identifique bem os acessórios antes de começar a montagem
- Não utilizar o artigo se um dos elementos está em falta ou danificado
- Para qualquer esclarecimento, contacte os nossos serviços através do telefone
- As instruções do fabricante devem ser sempre cumpridas
- Manutenção: limpe com um pano macio e seco. Em caso de manchas maiores, esfregue cuidadosamente com uma esponja ligeiramente húmida e não abrasiva
- **ATENÇÃO!** Não destinado a crianças menores de três anos. Peças pequenas. Risco de sufocamento.

ES - IMPORTANTE! CONSERVAR PARA FUTURAS CONSULTAS: LEER DETENIDAMENTE

- A montar por un adulto. Un adulto debe comprobar el buen montaje antes de la utilización
- ¡ADVERTENCIA! mantener los tornillos, los pequeños elementos y bolsitas fuera del alcance de los niños
- Identificar debidamente los elementos antes de empezar el montaje
- No utilizar este artículo si uno de los elementos falta o esta roto
- Si tiene problemas, contactar nuestro servicio postventa
- Deben seguirse siempre las instrucciones del fabricante
- Cuidados: limpiar con un paño suave y seco. En caso de manchas grandes, frotar con cuidado utilizando una esponja húmeda no abrasiva
- ¡ADVERTENCIA! No conveniente para niños menores de 3 años. Piezas pequeñas. Riesgo de asfixia.

DE - WICHTIG! FÜR SPÄTERE BEZUGNAHME AUFBEWAHREN: SORGFÄLTIG LESEN

- Von einem Erwachsenen zu montieren. Die korrekte Montage muss vor Gebrauch von einem Erwachsenen geprüft werden
- **ACHTUNG!** die Schrauben und kleinen Teile ausserhalb der Reichweite von Kindern lagern
- Vor Montagebeginn alle Teile identifizieren
- Ihren Artikel nicht benutzen, wenn eines seiner Bestandteile beschädigt ist oder fehlt
- Im Problemfall Ihren Kundendienst anrufen
- Stets die Herstelleranweisungen beachten
- **Wartung:** Mit einem weichen, trockenen Tuch reinigen. Bei größeren Flecken vorsichtig mit einem leicht feuchten, nicht scheuernden Schwamm abreiben
- **ACHTUNG!** Nicht für Kinder unter 3 Jahren. Kleine Teile. Erstickungsgefahr.

IT - IMPORTANTE! CONSERVARE QUESTE INFORMAZIONI PER ULTERIORI CONSULTAZIONI:





LEGGI ATTENTAMENTE



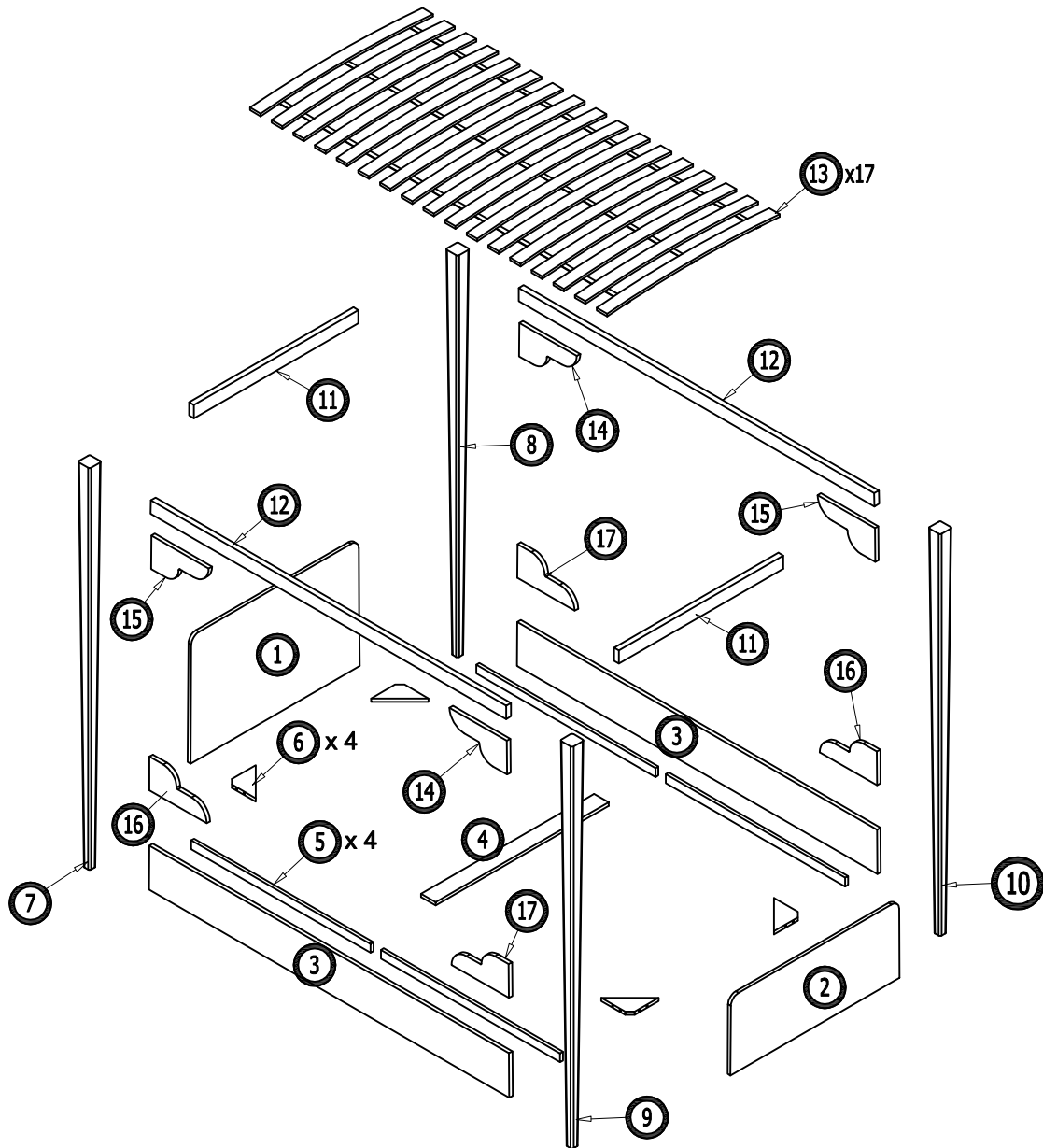

- Il montaggio deve essere eseguito da un adulto. Un adulto dovrà verificare il corretto montaggio prima dell'uso
- **ATTENZIONE!** tenere le viti ed i componenti di piccole dimensioni lontano dalla portata dei bambini
- Controllare i pezzi prima del montaggio
- L'articolo non deve essere utilizzato in caso di elementi mancanti o danneggiati
- In caso di necessità contattare il nostro servizio post-vendita
- Seguire sempre le istruzioni del costruttore
- **Manutenzione:** pulire con un panno morbido e asciutto. Per le macchine più grandi, strofinare accuratamente con una spugna leggermente umida e non abrasiva
- **ATTENZIONE!** Non adatto a bambini di età inferiore a 3 anni. Piccoli pezzi. Rischio di soffocamento.

NL - BELANGRIJK! BEWAAR VOOR LATERE RAADPLEGING: LEES AANDACHTIG

- Moet door een volwassene worden gemonteerd. Voor gebruik moet een volwassene controleren dat het product goed in elkaar is gezet
- **WAARSCHUWING!** schroeven en kleine elementen en zakjes buiten bereik van kinderen houden
- De elementen goed identificeren alvorens met de montage te beginnen
- Uw artikel niet gebruiken wanneer een van de onderdelen kapot is of ontbreekt
- Neem bij problemen contact op met onze klantenservice
- Volg altijd de instructies van de fabrikant
- **Onderhoud:** maak schoon met een zachte en droge doek. In geval van grotere vlekken, veeg voorzichtig schoon met een licht bevochtigde en niet-schurende spons
- **WAARSCHUWING!** Is niet geschikt voor kinderen van jonger dan 3 jaar. Kleine onderdelen. Verstikkingsgevaar.

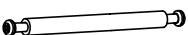



ITEM	HARDWARE	DESCRIPTION	Q'TY
A		Ø5 x 45 mm	26 PCS
B		Ø14.5 x 11.9 mm	34 PCS
C		Ø8 x 30 mm	44 PCS
D		Ø6 x 80 mm	12 PCS
E		Ø9.5 x 13 mm	12 PCS

ITEM	HARDWARE	DESCRIPTION	Q'TY
F		Ø6.6 x 68 mm	4 PCS
G		Ø6 x 80 mm	8 PCS
H		CLEF ALLEN	1 PC
K		Ø4 x 30 mm	20 PCS
L		Ø6 x 30 mm	8 PCS

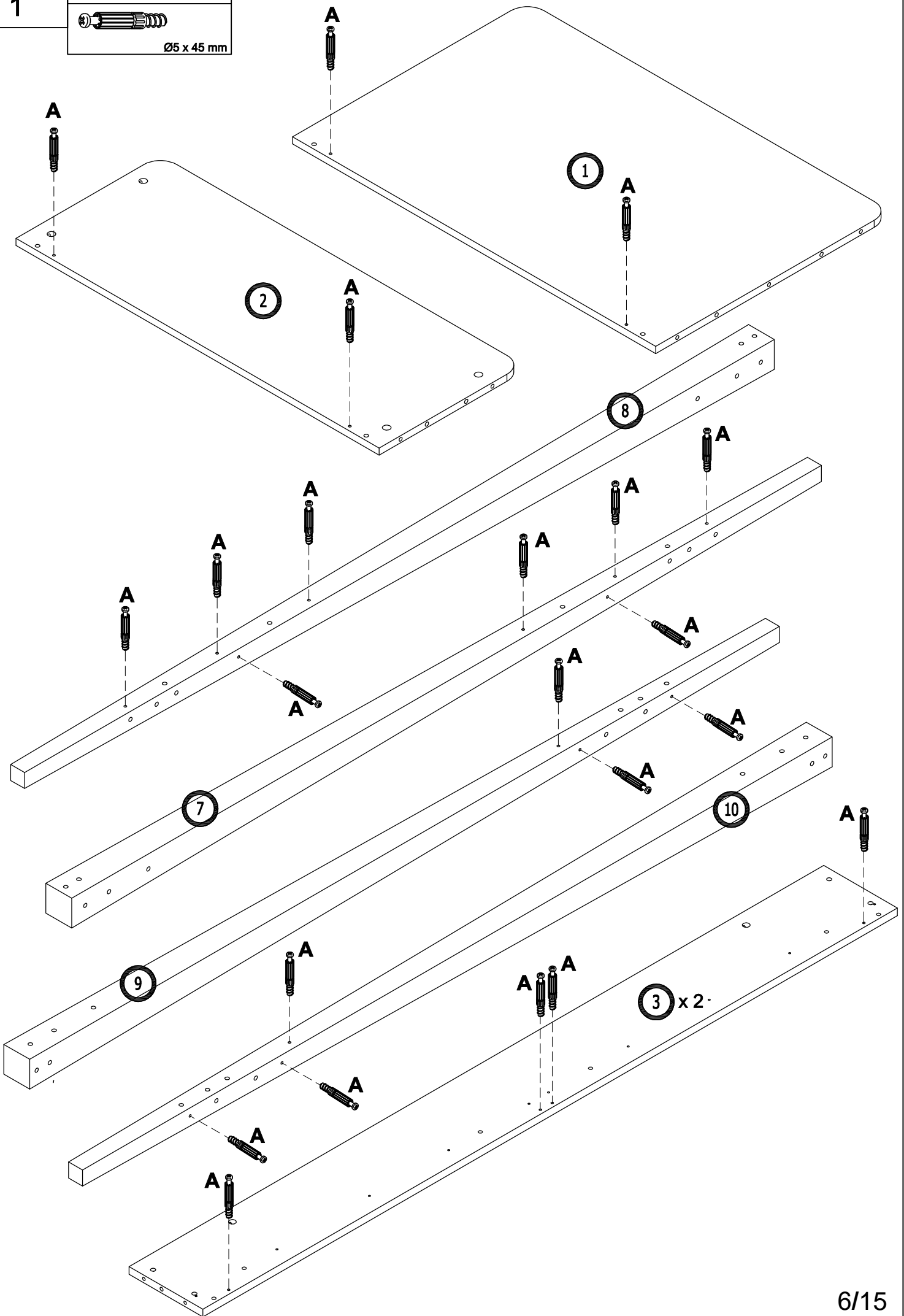
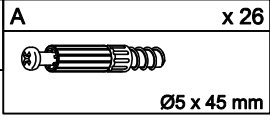
1





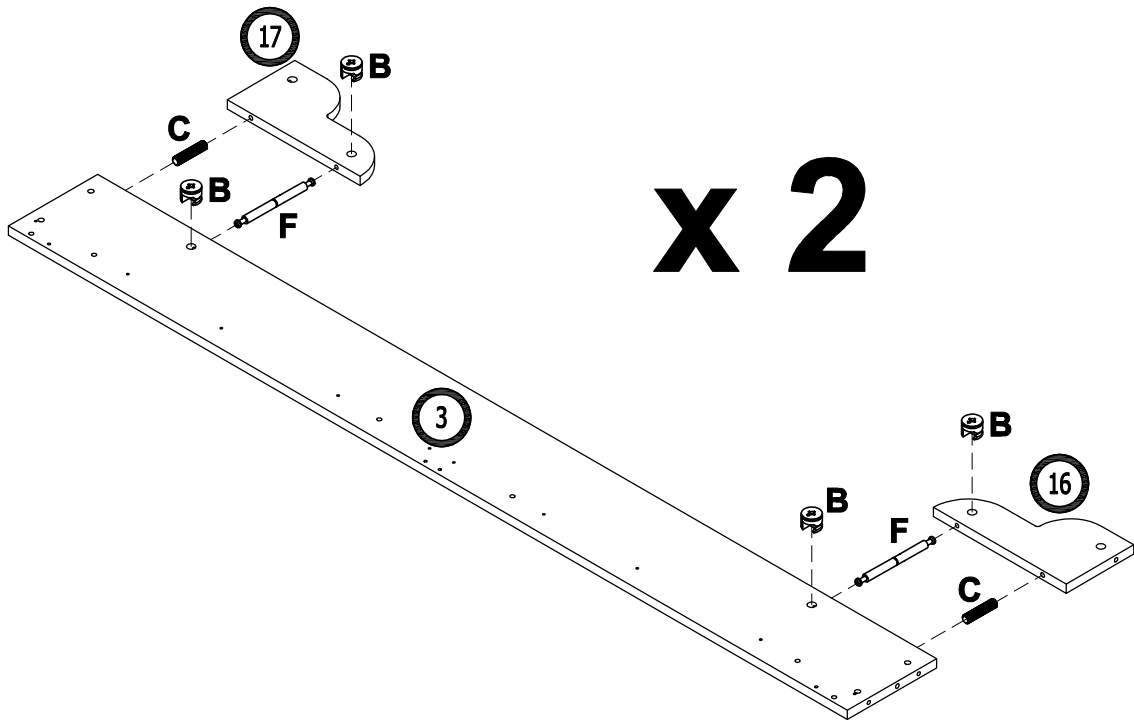

2

B	x 8	C	x 4	F	x 4
					
Ø14.5 x 11.9 mm		Ø8 x 30 mm		Ø6.6 x 68 mm	



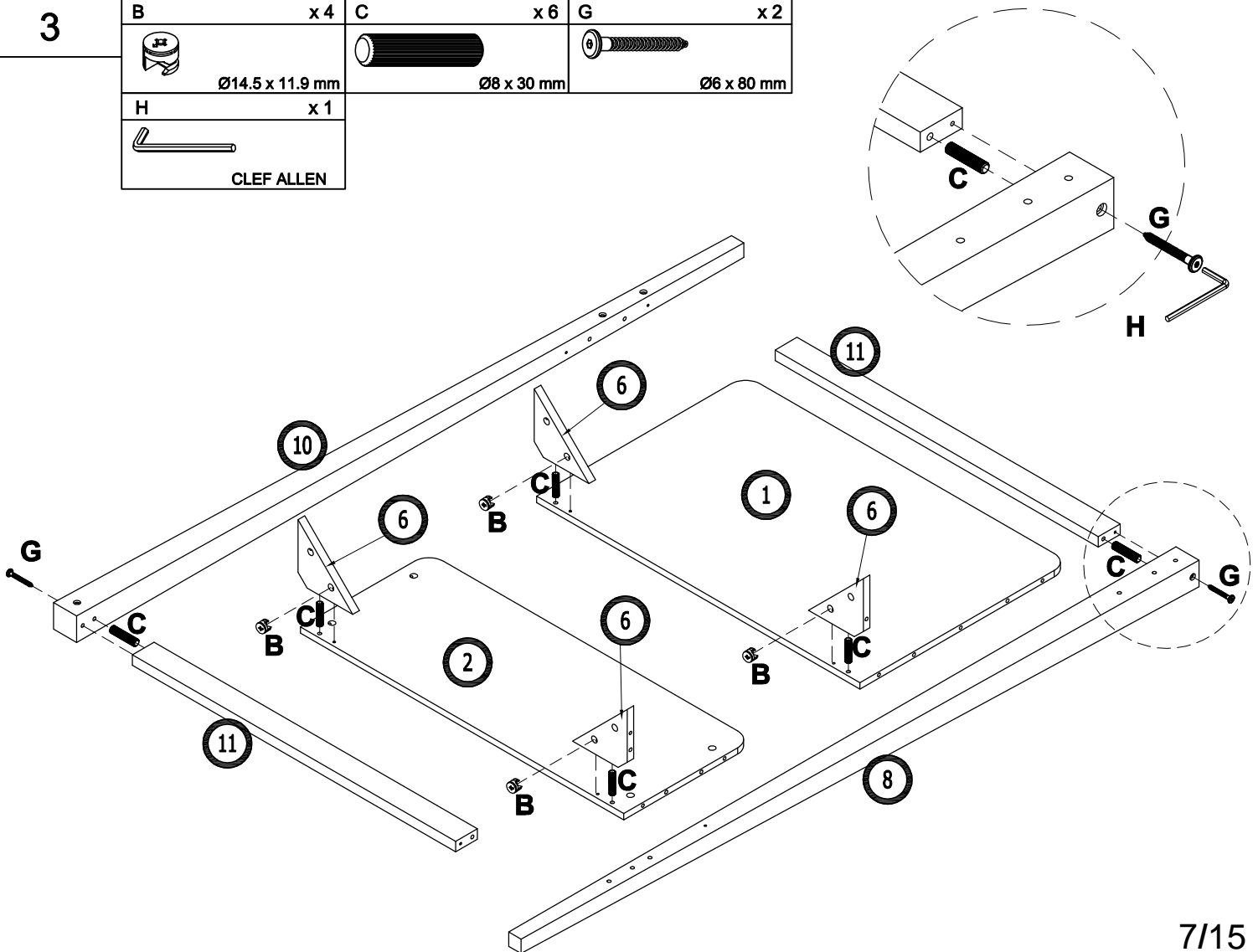

3

B	x 4	C	x 6	G	x 2
					
Ø14.5 x 11.9 mm		Ø8 x 30 mm		Ø6 x 80 mm	
H	x 1				
					
CLEF ALLEN					

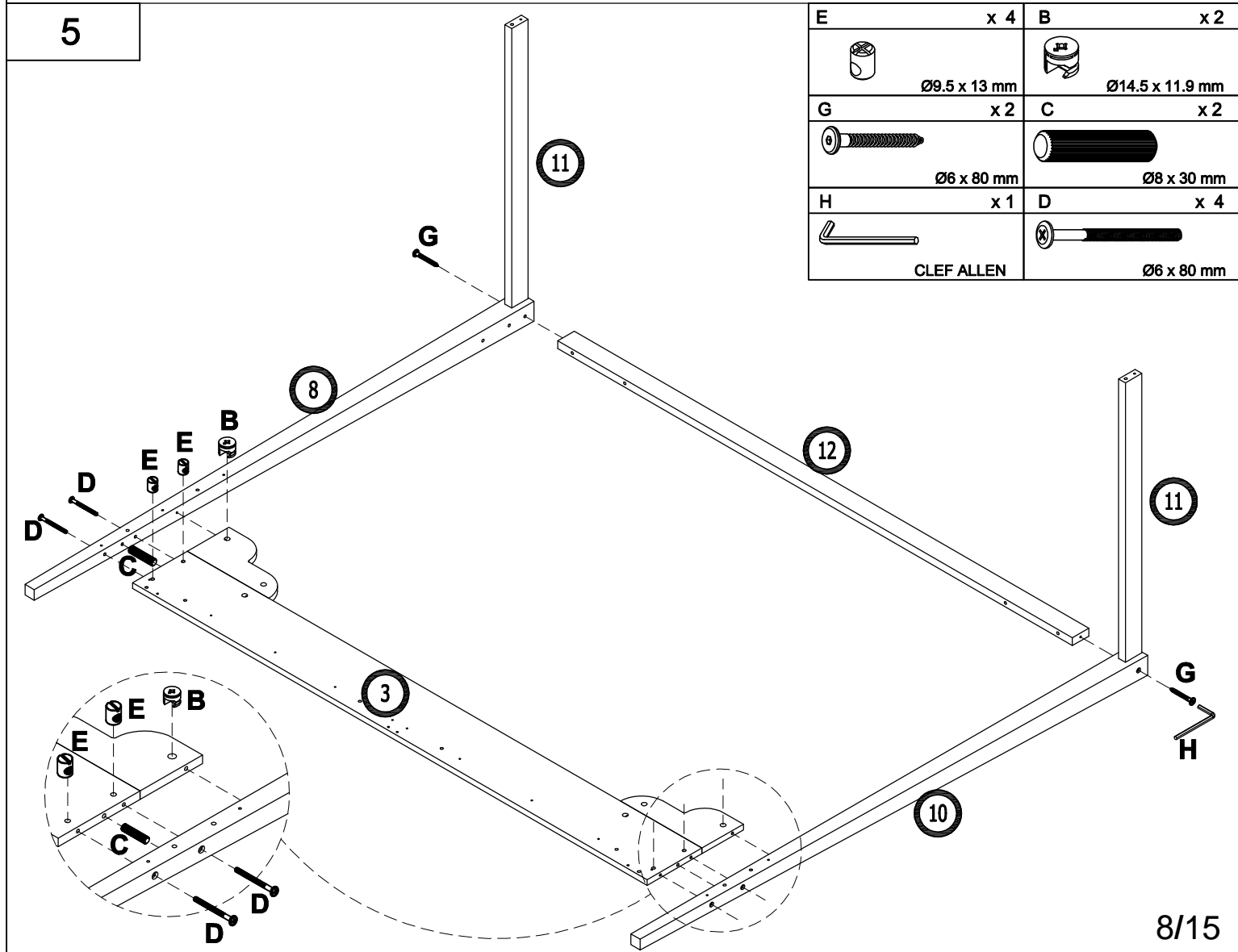
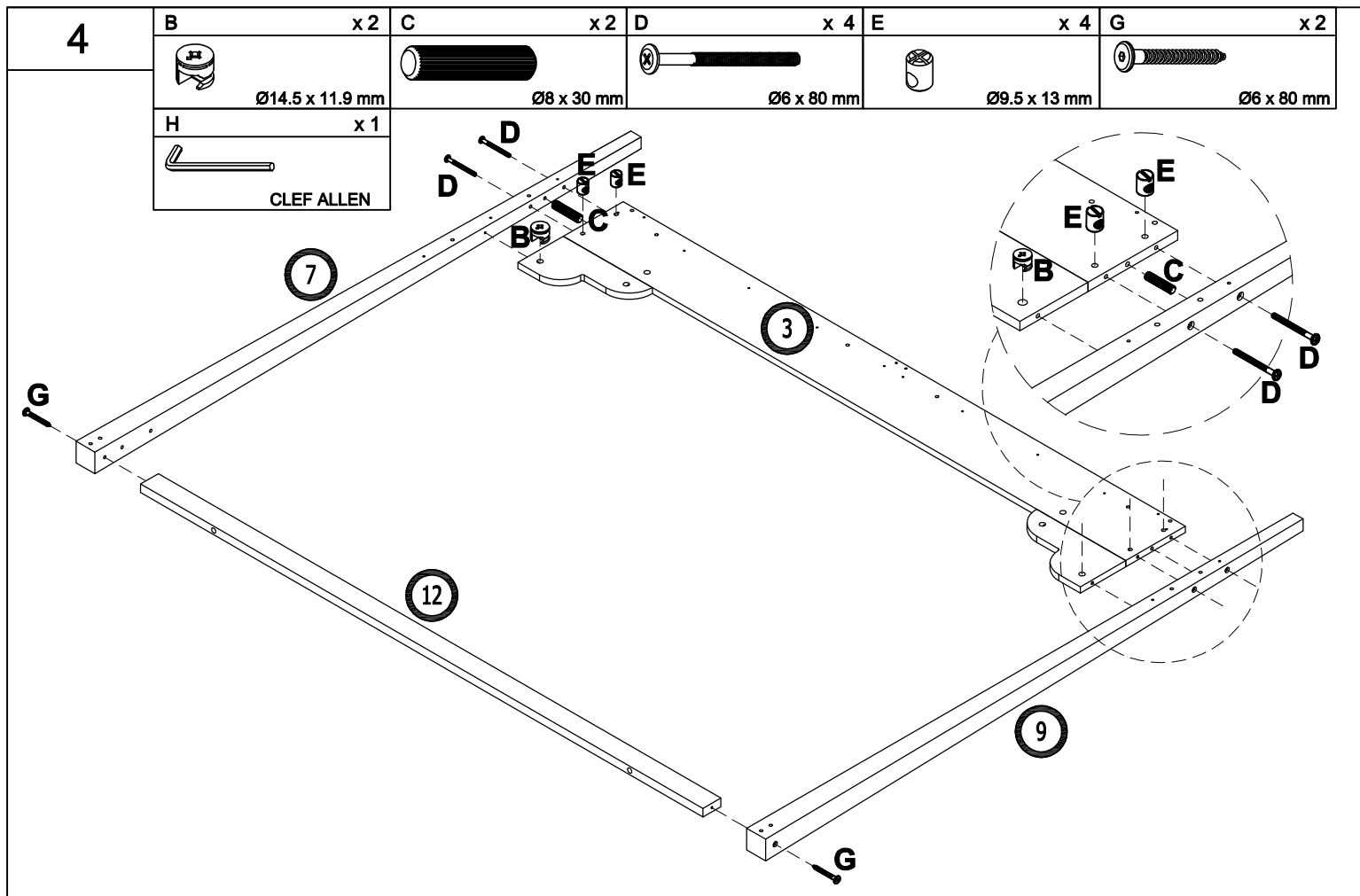





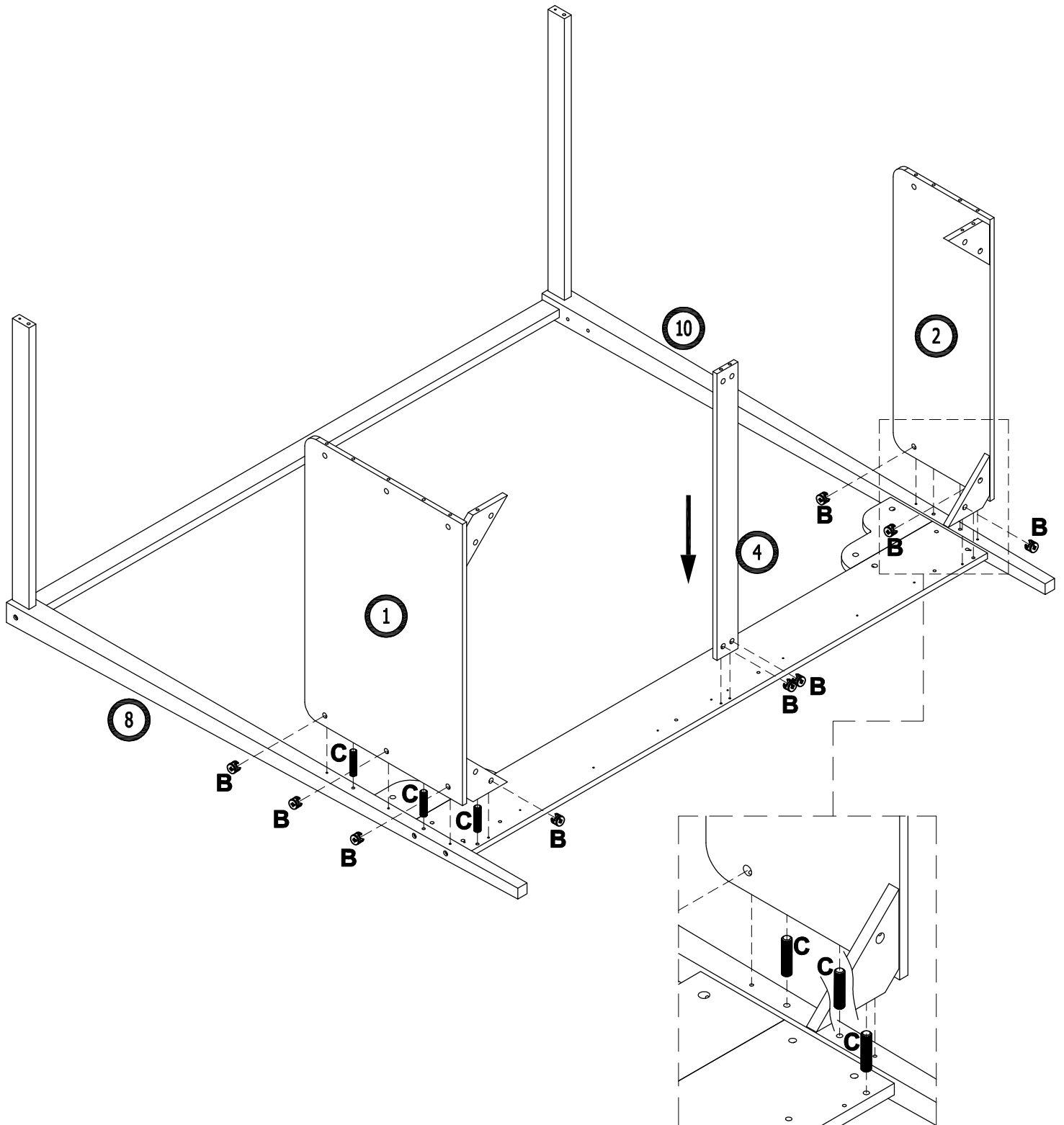

6

B	x 9	C	x 6
			
Ø14.5 x 11.9 mm		Ø8 x 30 mm	



7

B	x 9	C	x 8	G	x 2	H	x 1
							
Ø14.5 x 11.9 mm		Ø8 x 30 mm		Ø6 x 80 mm		CLEF ALLEN	

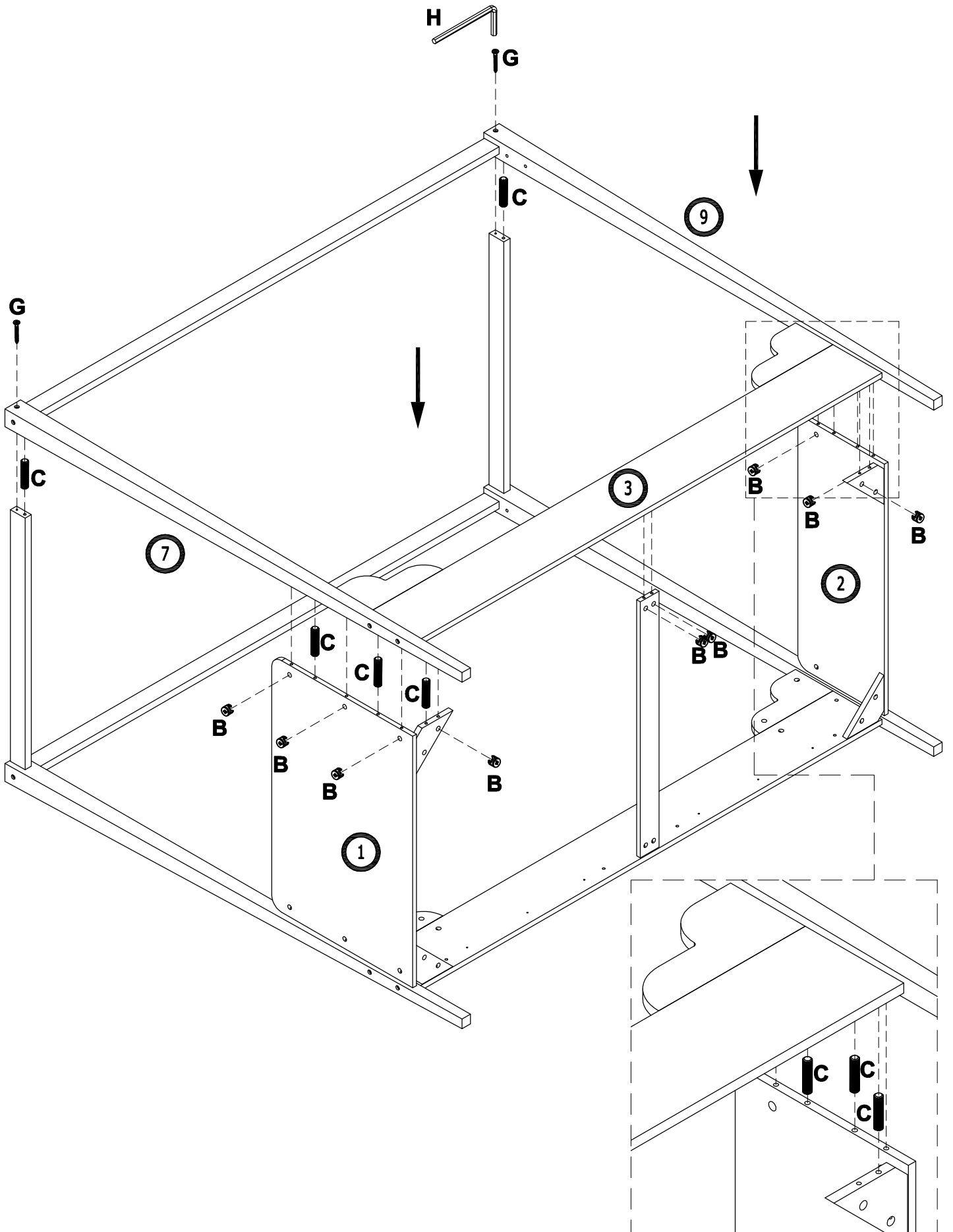

8

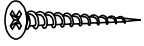
C	x 8	K	x 20
			
Ø8 x 30 mm		Ø4 x 30 mm	

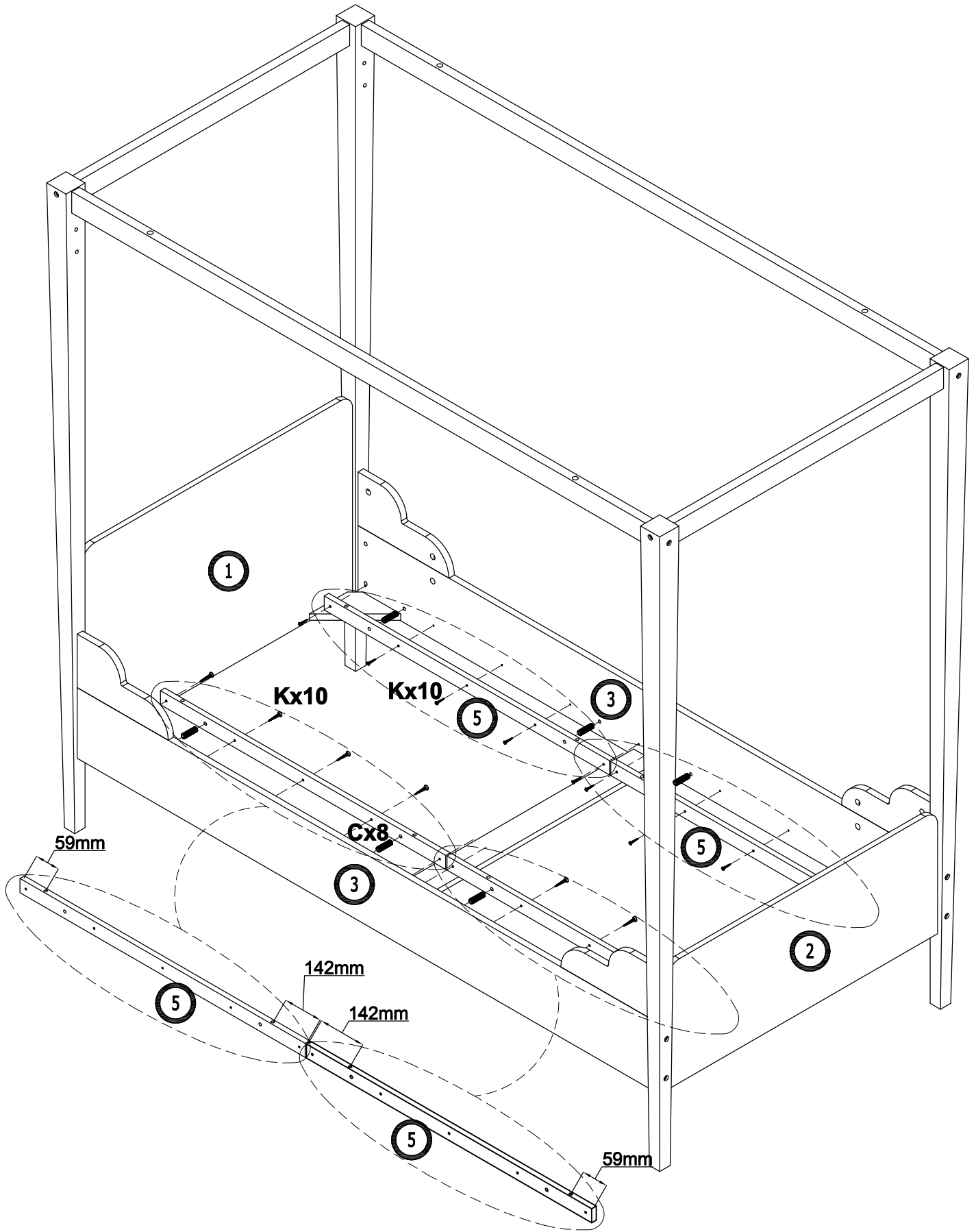

9

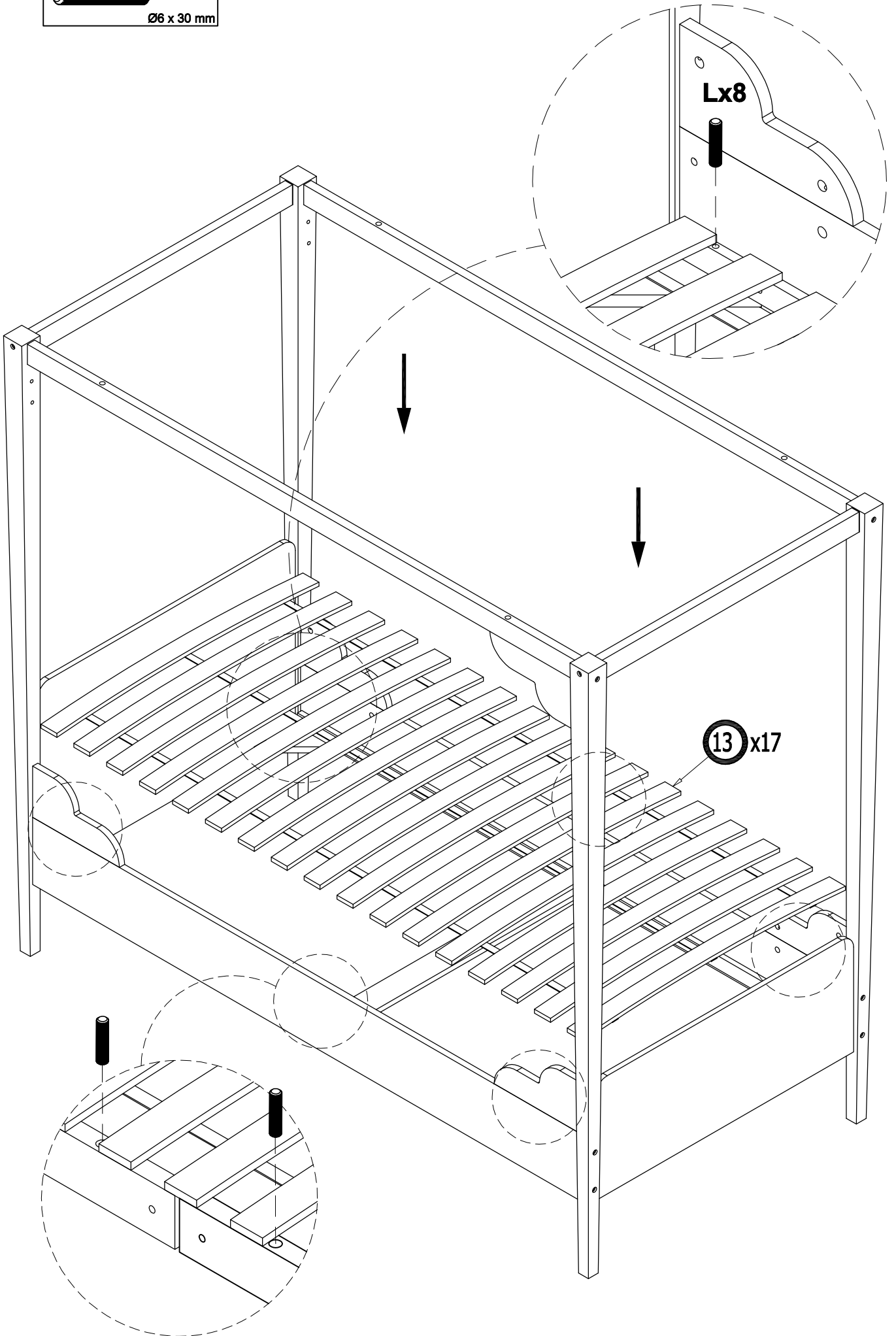

L x 8
Ø6 x 30 mm

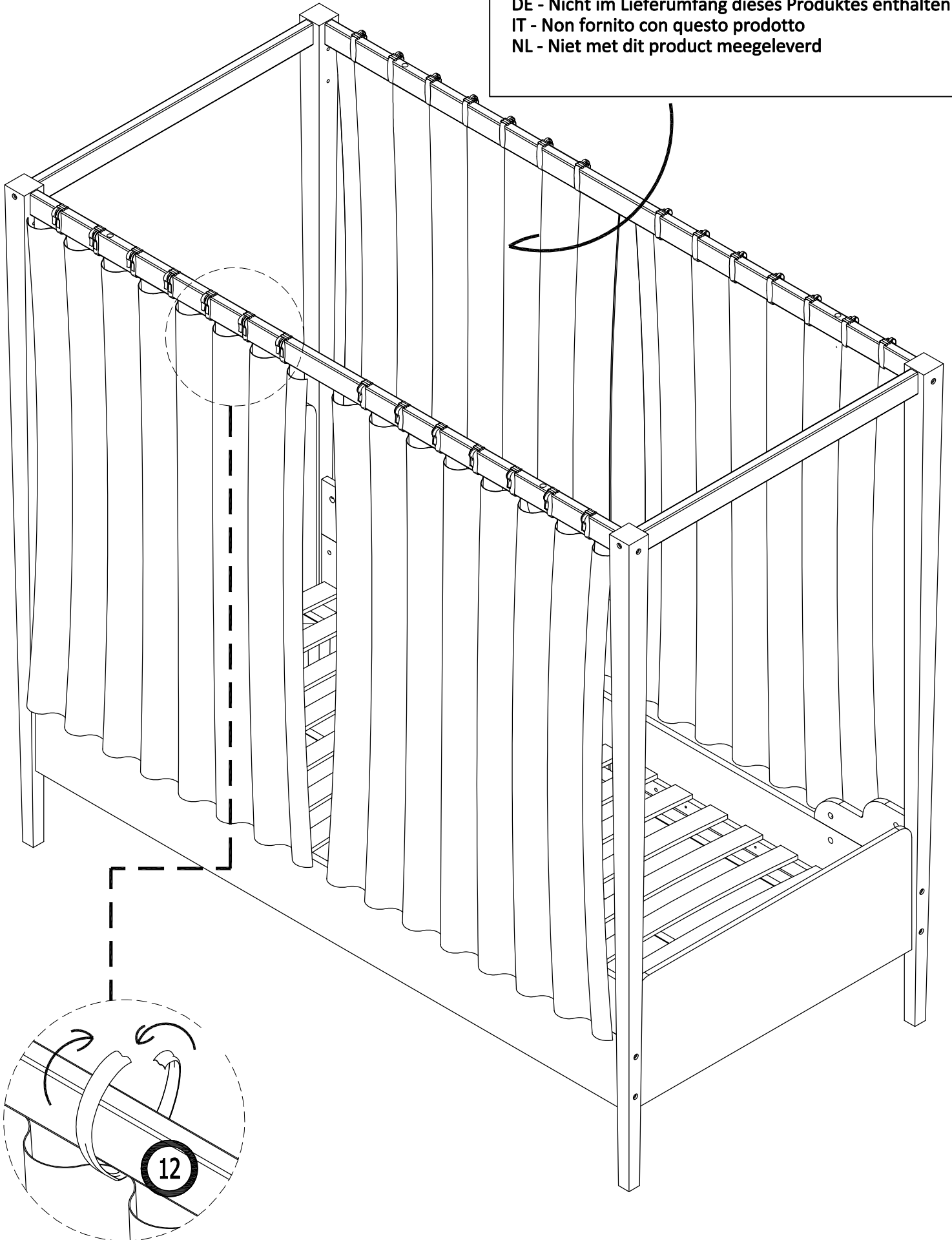

FR - Non fourni avec ce produit
EN - Not supplied with this product
PT - Não fornecido com este produto
ES - No se incluye con este producto
DE - Nicht im Lieferumfang dieses Produktes enthalten
IT - Non fornito con questo prodotto
NL - Niet met dit product meegeleverd



11

C	x 8	D	x 4
			
Ø8 x 30 mm		Ø6 x 80 mm	
E	x 4		
			
Ø9.5 x 13 mm			

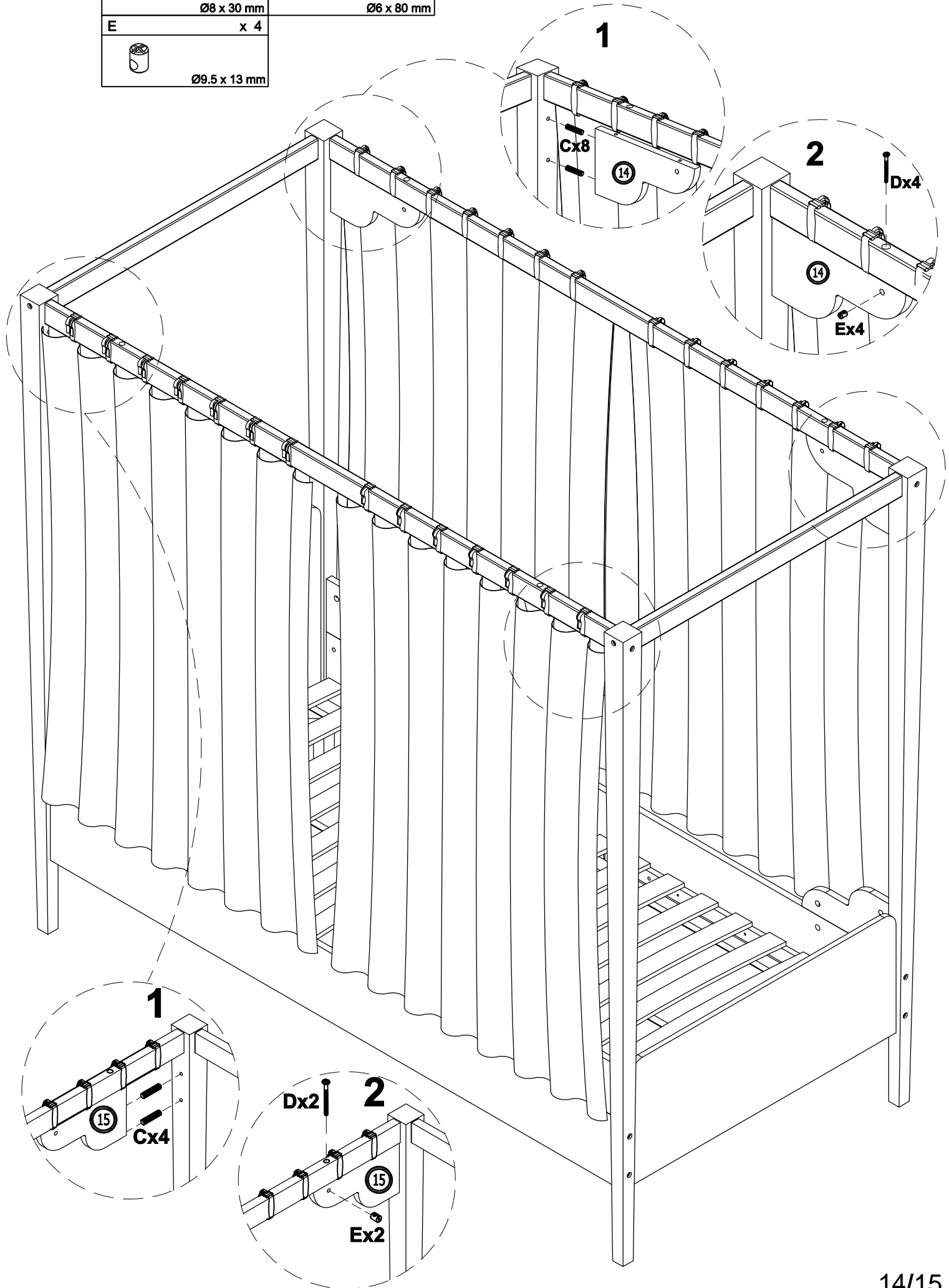

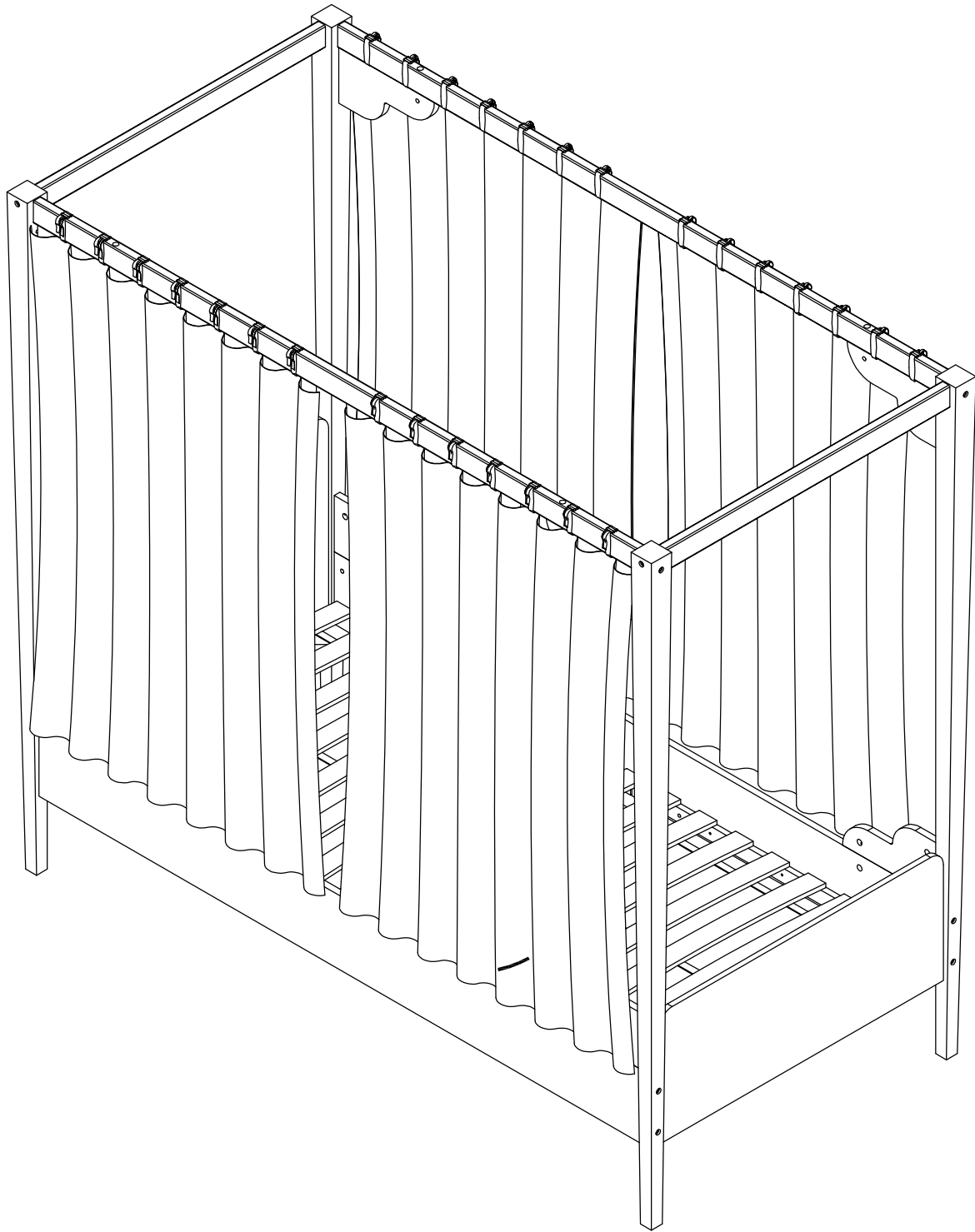

FR-Importé par / EN- Imported by / PT-importado por / ES-importado por / DE-Importiert von /
IT-Importato da / NL-Geïmporteerd door :

UE/EU : Vertbaudet SAS - 216, Rue Winoc Chocqueel, 59200 Tourcoing , France

UK : Vertbaudet UK Limited - Elder House, St Georges Business Park, 207 Brooklands Road,
Weybridge, Surrey KT13 0TS

